



by **LR UMBRARIMORCHI**
TOWBARS AND TRAILERS

www.umbrarimorchi.it
umbrarimorchi@umbrarimorchi.it
Tel. +39 075 5280260
Fax +39 075 5287033



FORD TRANSIT
Furgone
Van

[2014+]

DEXTER 560 TREND 4x4



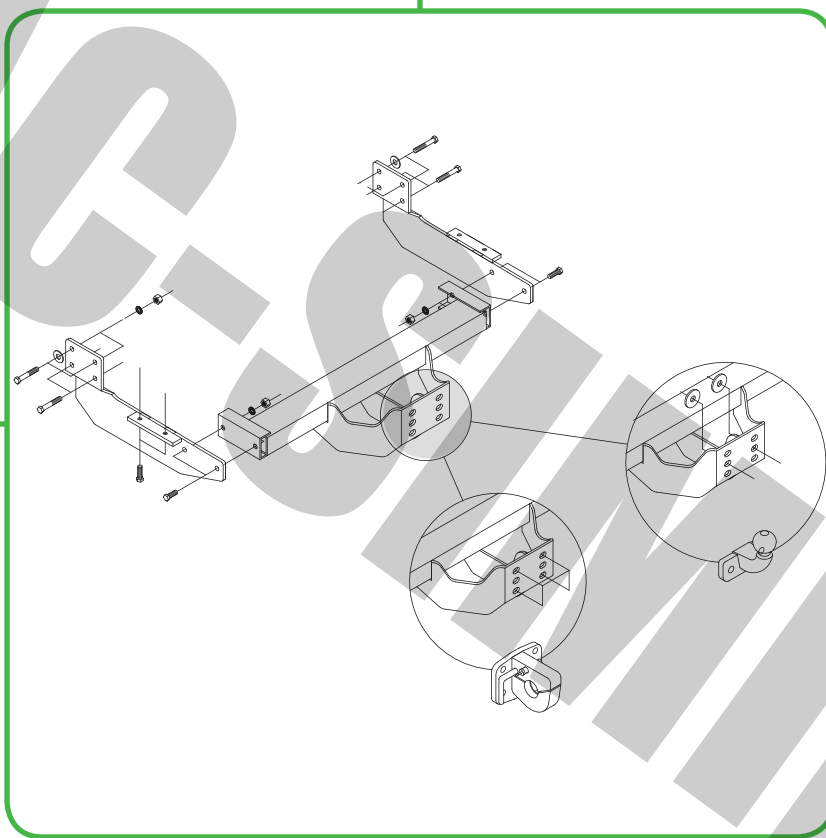

[2014+]

14092



FONT VENDOME FORTY VAN 4x4 [2014+]





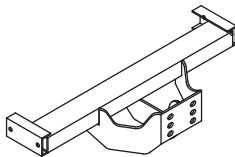
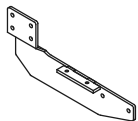
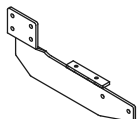

14092

	<p>FORD TRANSIT [2014+] Furgone Van</p> <p>DEXTER 560 TREND 4x4 [2014+]</p> <p>FONT VENDOME FORTY VAN 4x4 [2014+]</p>
<p>TYPE</p>	<p>FCD, FAD, FED, PVDLFO, PVD</p>
 kg	<p>S = 140</p>
<p>EC</p>	<p>E3 55R-01 7802 Regolamento UN/ECE 55.01</p>
 Nm	<p>M6 = 10 M12 = 85 M8 = 25 M14 = 135 M10 = 55 M16 = 200</p>
<p>D kN</p>	<p> $\frac{\begin{matrix} \text{MAX} \downarrow \text{Kg} & \text{MAX} \downarrow \text{Kg} \\ \text{Car} \times \text{Tool} \end{matrix}}{\begin{matrix} \text{MAX} \downarrow \text{Kg} & \text{MAX} \downarrow \text{Kg} \\ \text{Car} + \text{Tool} \end{matrix}} \times 0,00981 \leq 17,17$ </p>
	<p>F</p>

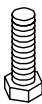
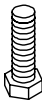
14092



A	1 x	081409020300150000	
B	1 x	081409230300550000	
C	1 x	081409230300650000	
D	2 x	0814090010300750000	

1	4 x	M12x35	
2	4 x	M12x90	
3	4 x	14x28x2.5	
4	8 x	12x27x2	
5	8 x	M12	

6

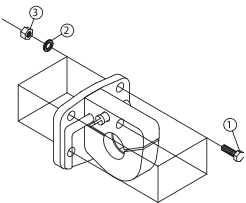
G





1	4x	M10x35 (8.8)	
2	4x	10x22x1,5	
3	4x	M10 (8.8)	

GRIFO
DGM*7*0001 G2

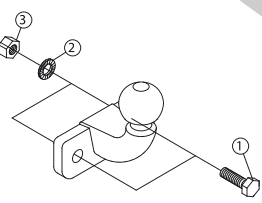
SF



1	2x	M14x40 (8.8)	
2	2x	14x28x2,5	
3	2x	M14 (8.8)	

TB-1
e6 94/20 010100
E6 55R-01 0930 ext00

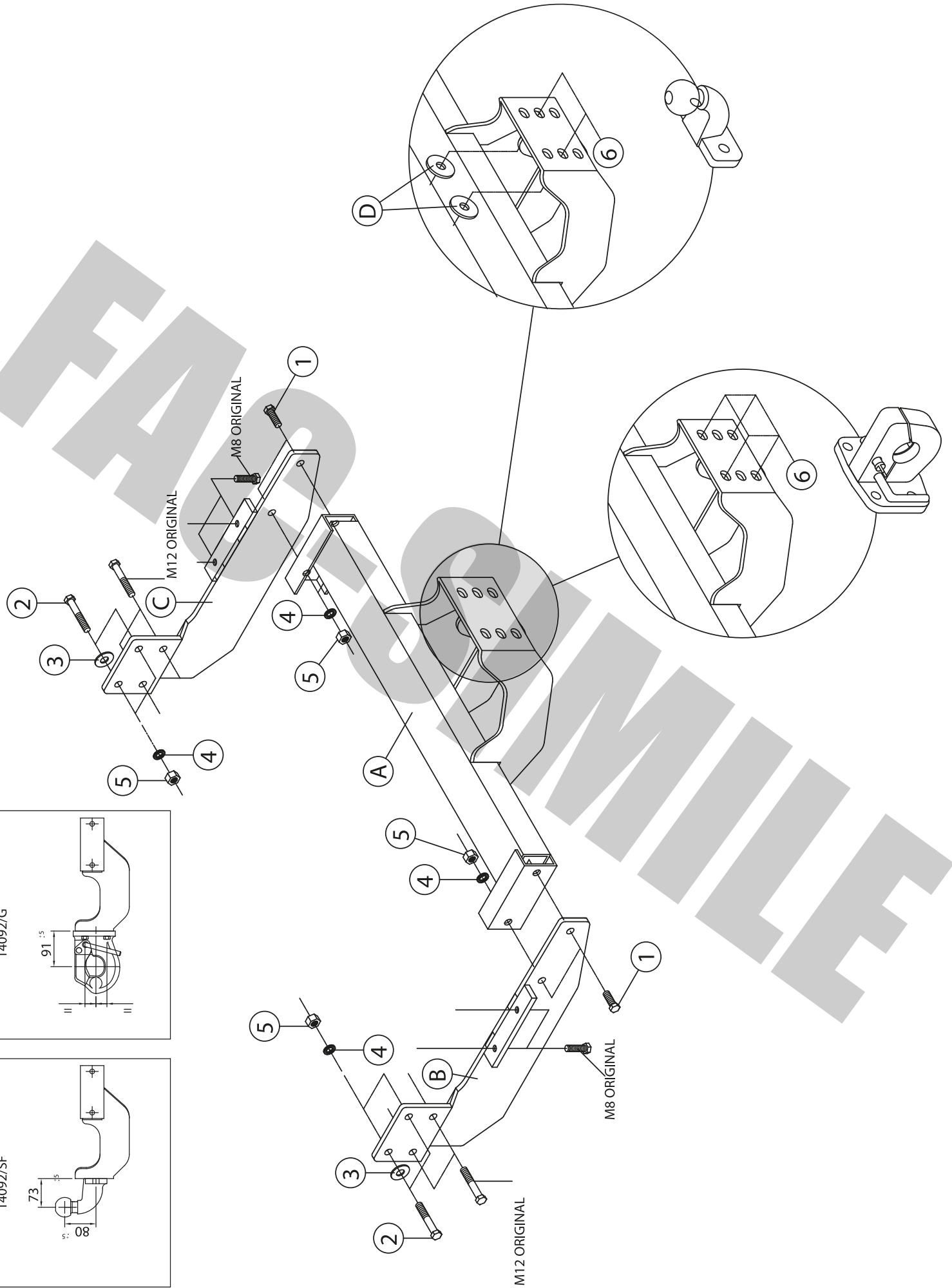
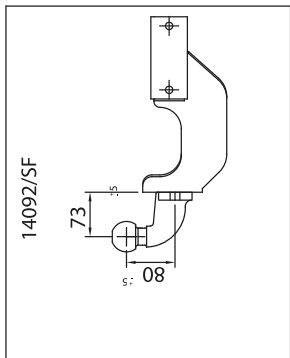
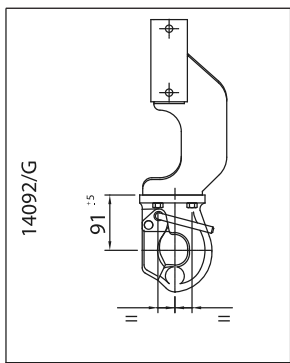

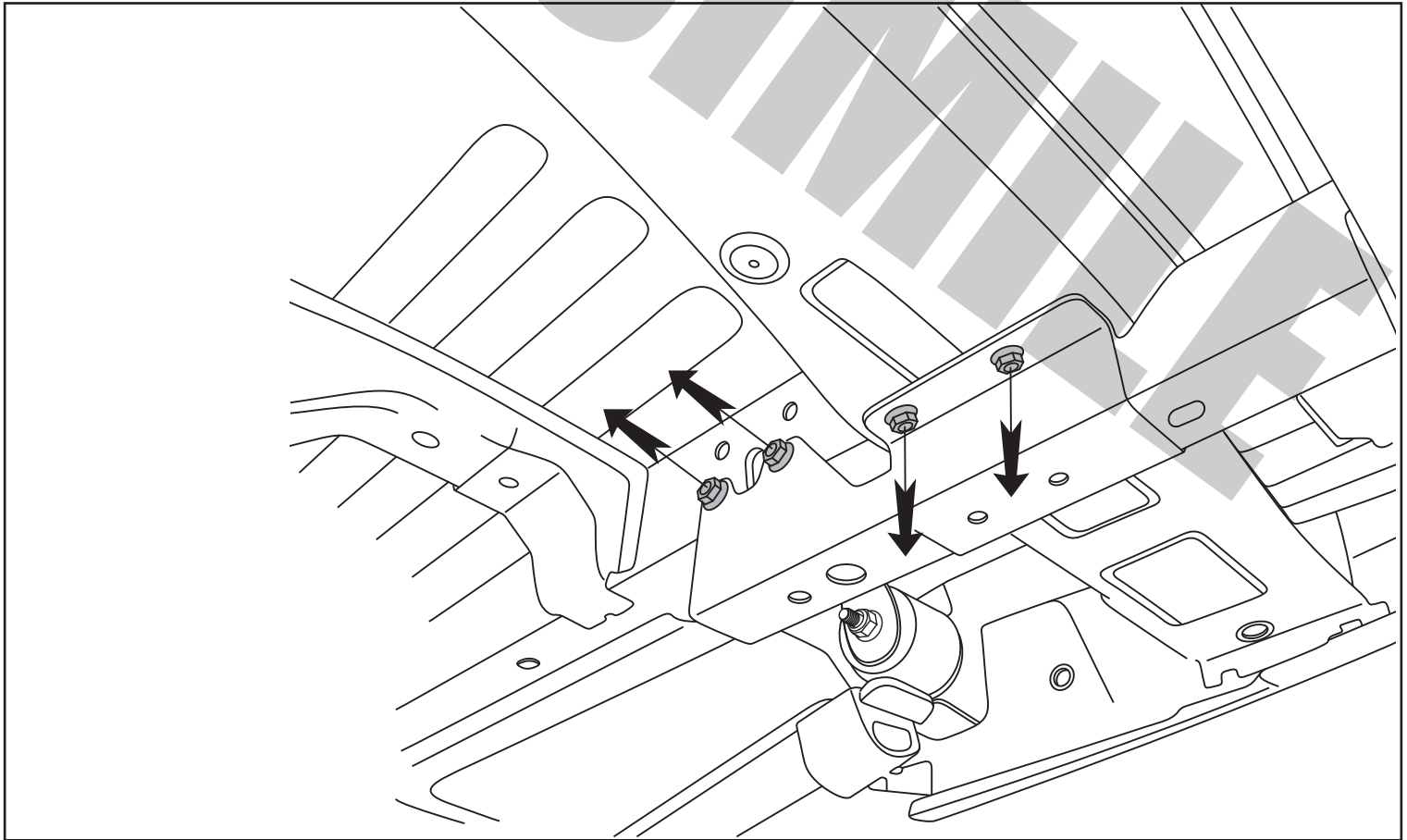
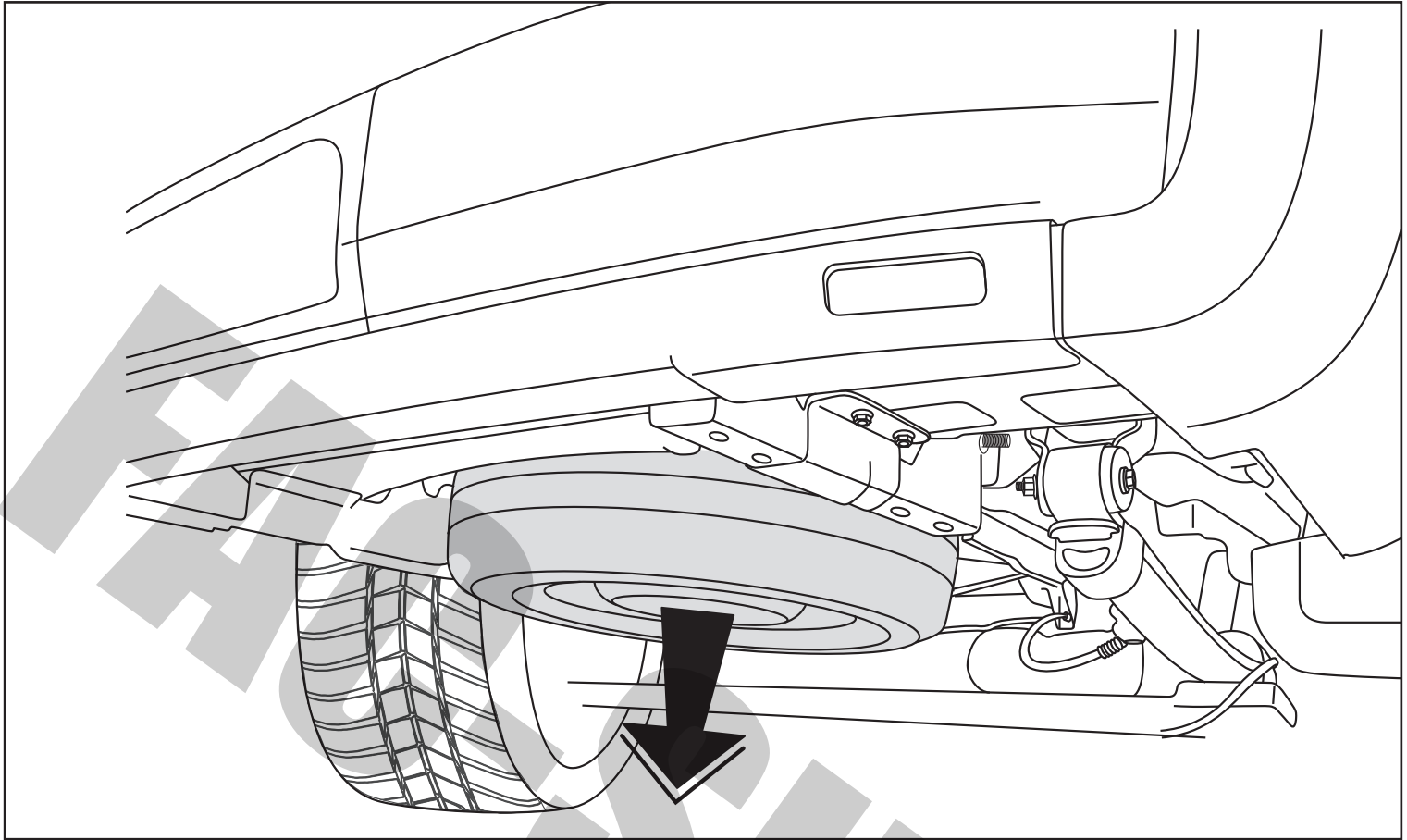



x2



12x36

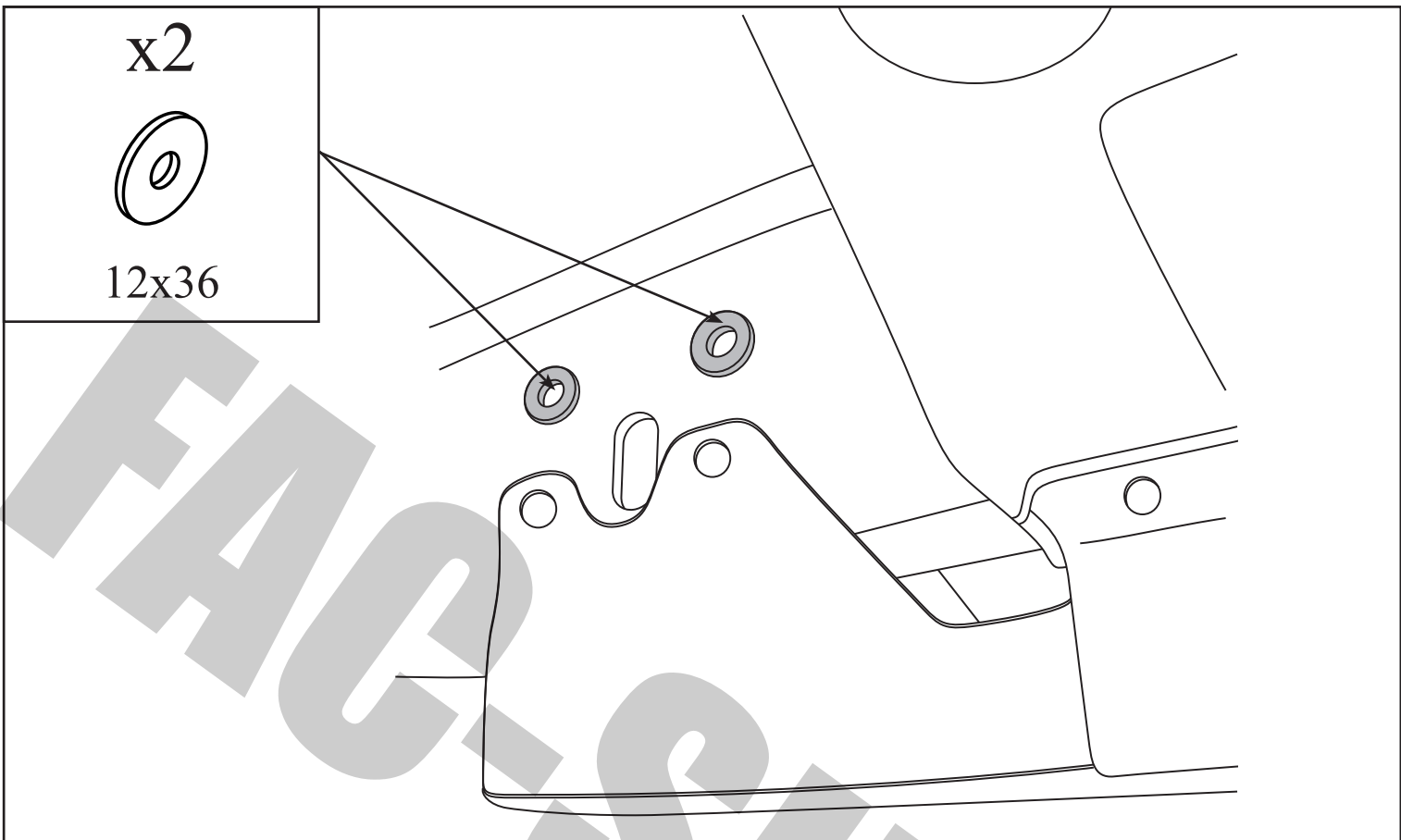

x2



12x36

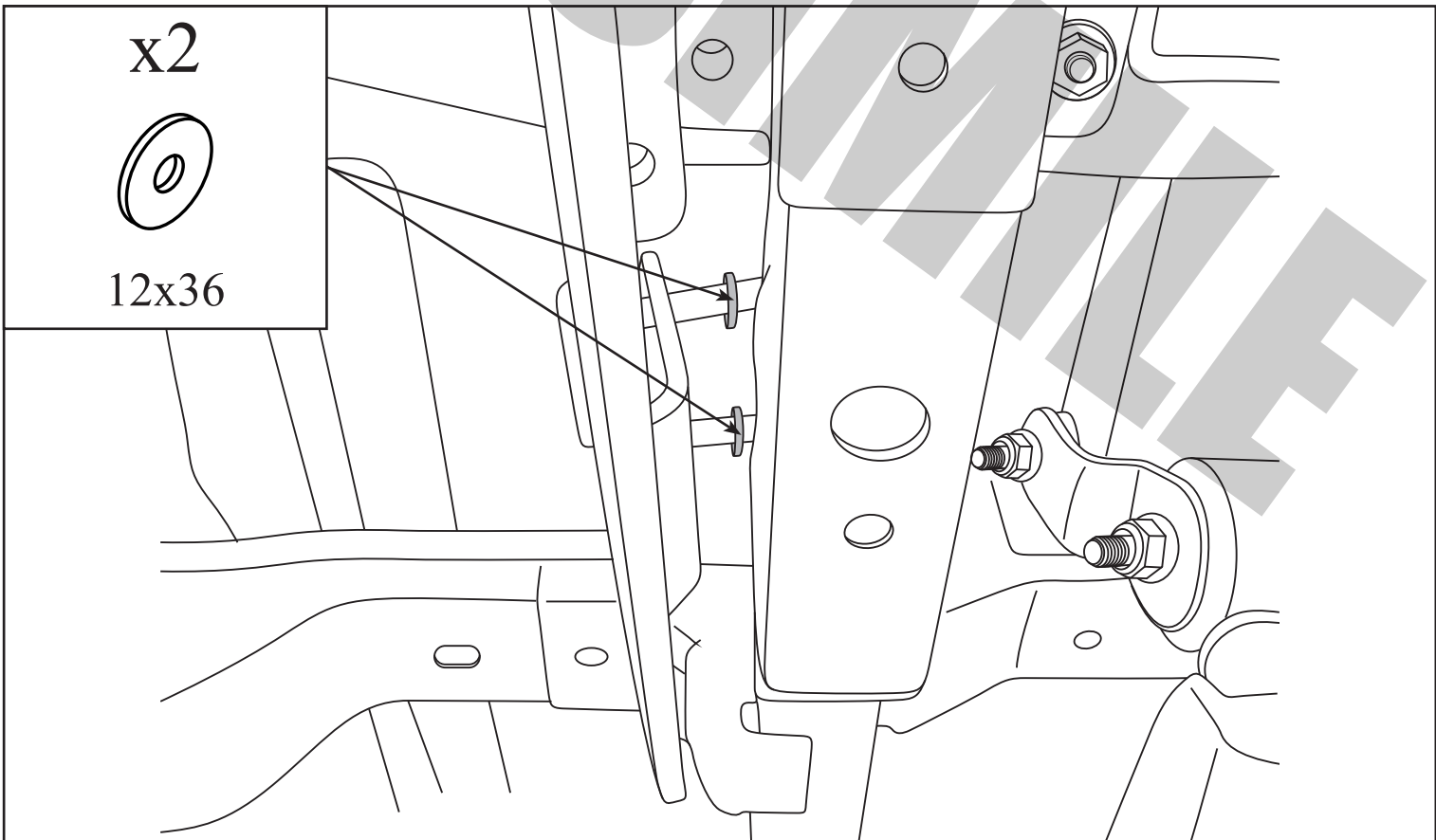

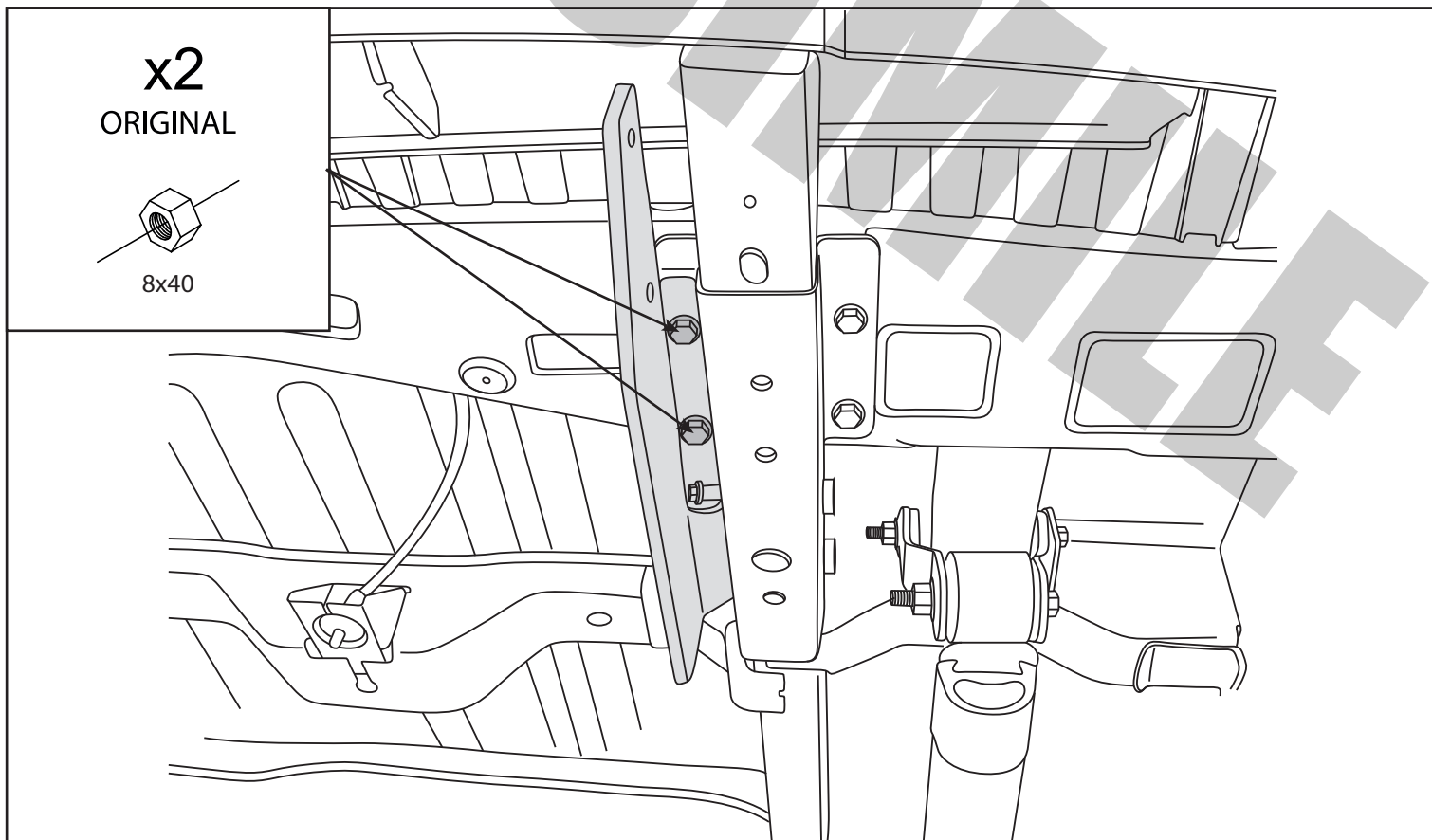
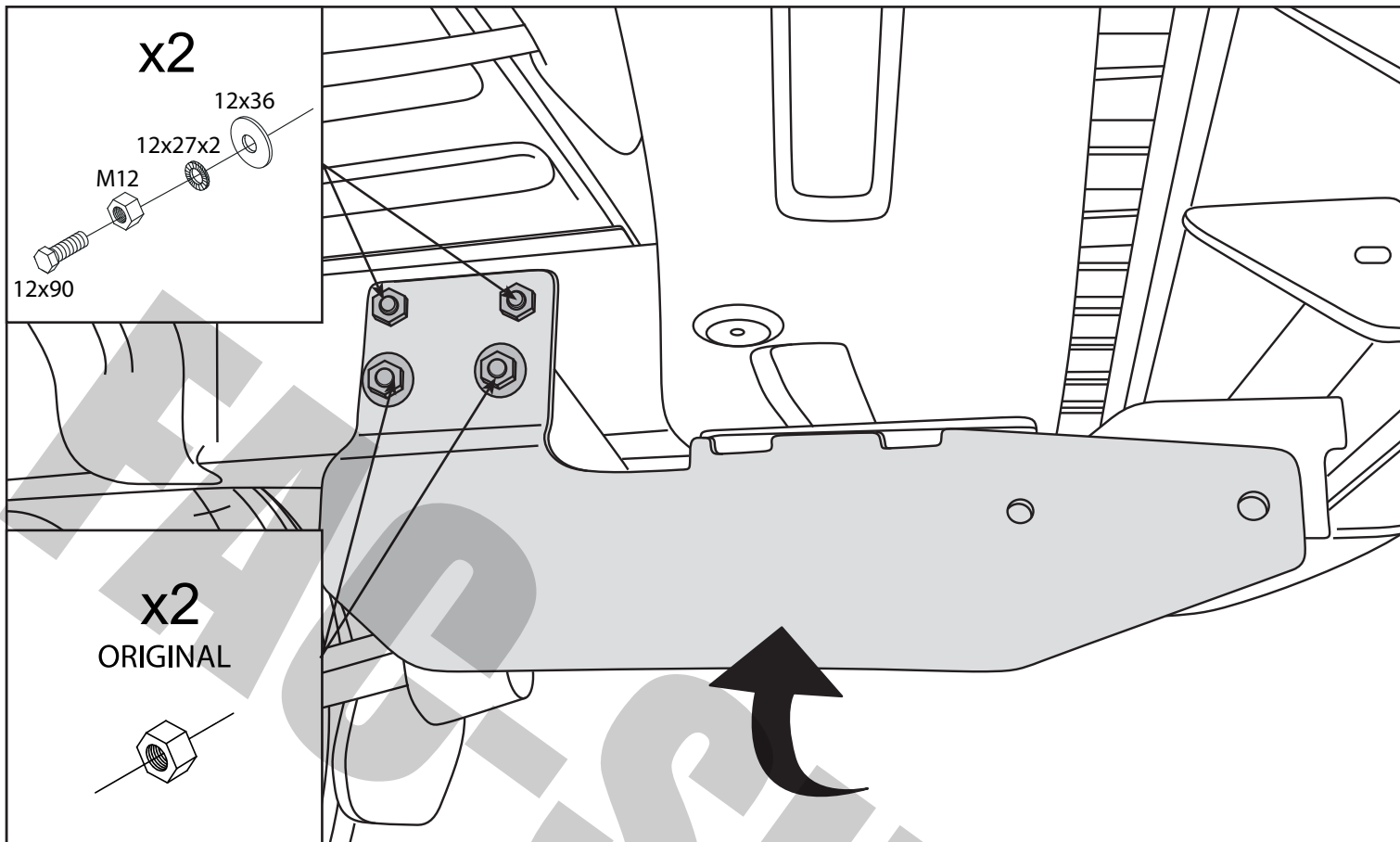

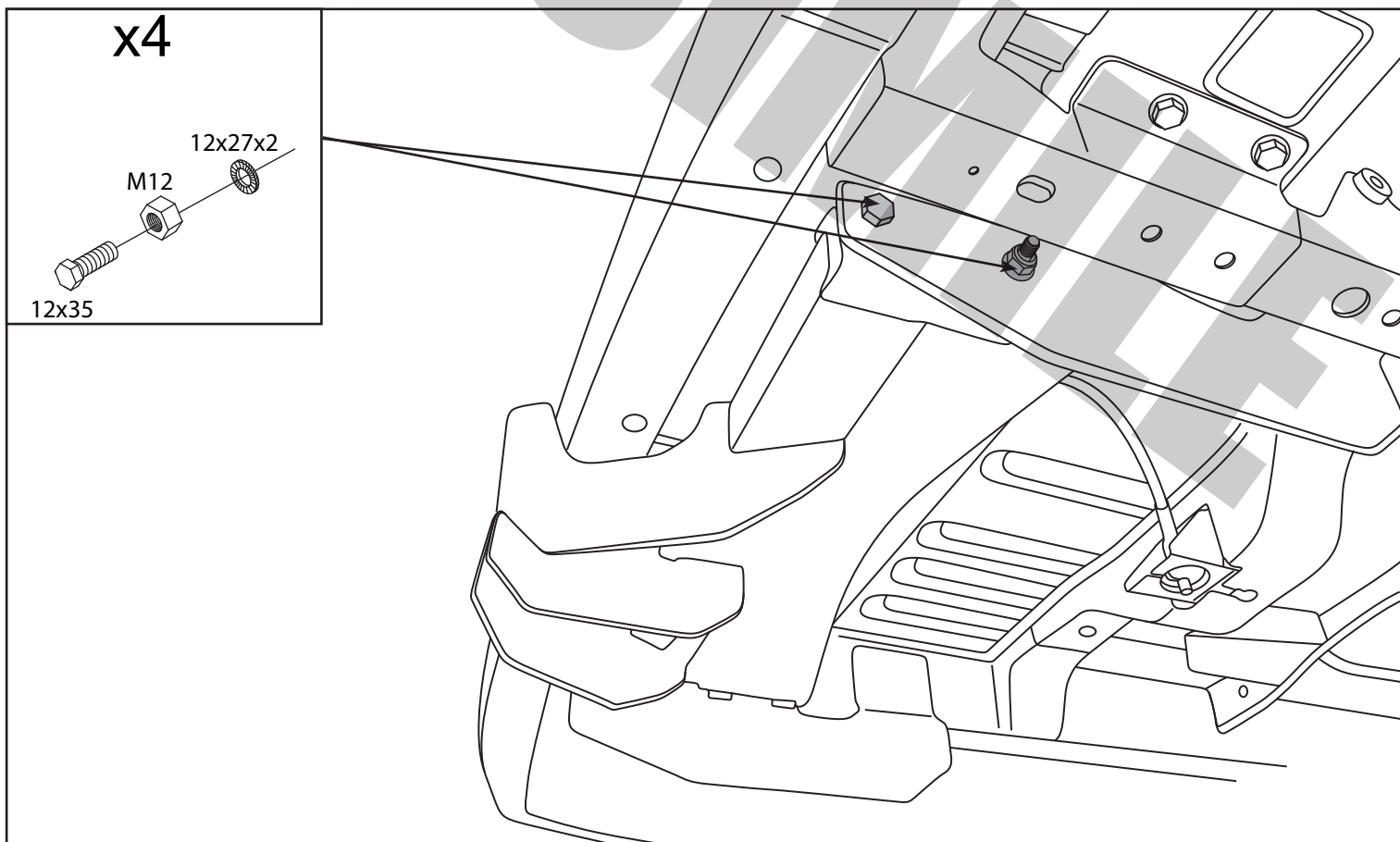
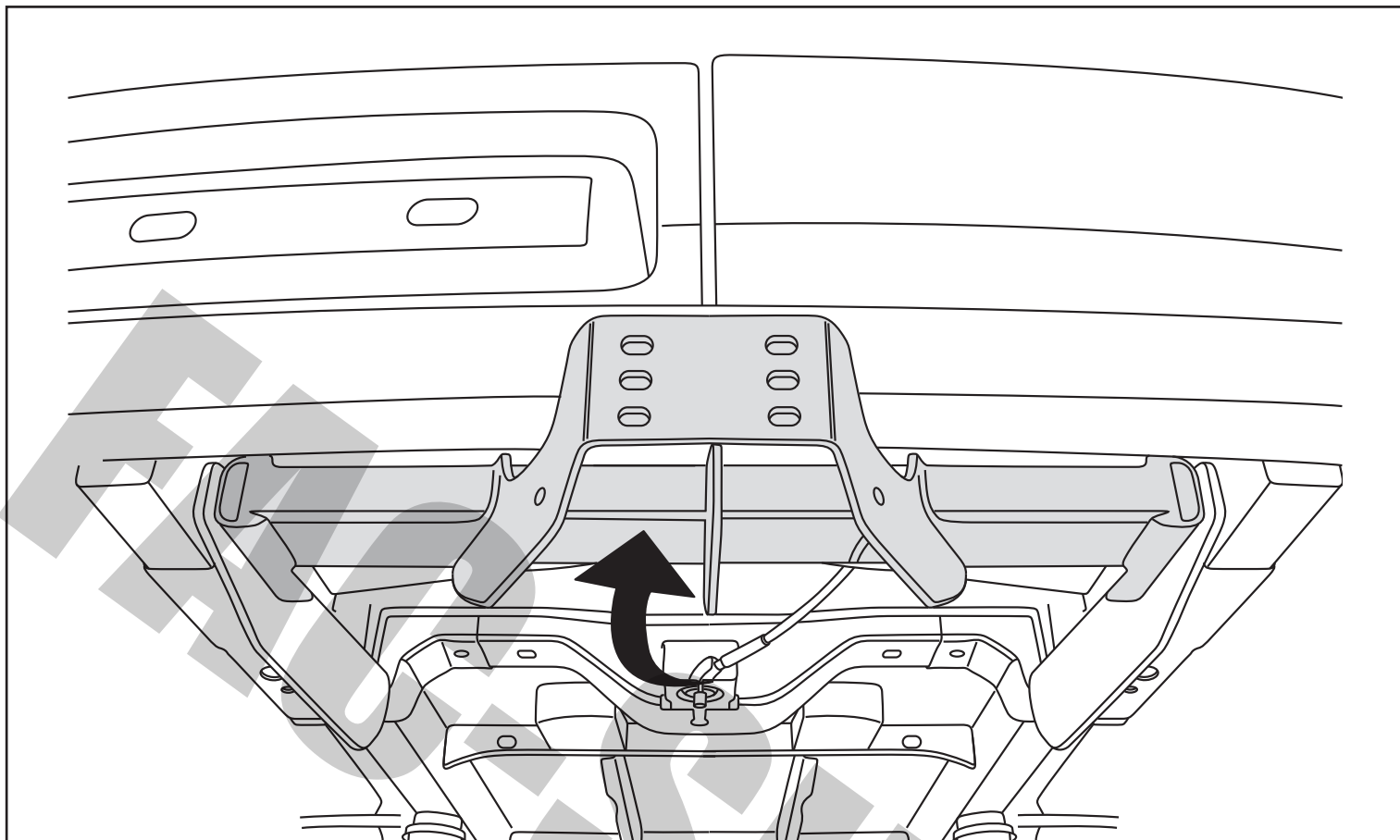

FOGLIO DA PRESENTARE PER IL COLLAUDO

DISPOSITIVO DI TRAINO TIPO: 14092	
PER AUTOVEICOLO: FORD TRANSIT	[2014+]
Furgone Van	
DEXTER 560 TREND 4X4	[2014+]
FONT VENDOME FORTY VAN	[2014+]
TIPO FUNZIONALE: FCD ?????????? ??????????????, FAD ?????????? ??????????????, FAD ?????????? ??????????????, FED ?????????? ??????????????, PVDLFO ???? ??????????????, FCD ?????????? ??????????????, PVD??? ???? ??????????????	
CLASSE E TIPO DI ATTACCO: F	
OMOLOGAZIONE: E3 55R-01 7802 Regolamento UN/ECE 55.01)	
VALORE D: kN 17,17	
CARICO VERTICALE MAX. S: Kg 140	
CARICO STATICO SU SFERA: Kg 112	
LARGHEZZA MAX RIMORCHIABILE: m 2,55	
MASSA RIMORCHIABILE: (vedere nella carta di circolazione del veicolo)	

In base al Regolamento UN/ECE 55.01, la massa rimorchiabile del dispositivo di traino è determinata dal valore "D" dalla formula:

$$D = (T \times R) / (T + R) \times 0,00981 = \text{kN} \dots\dots$$

$$D = (\dots\dots \times \dots\dots) / (\dots\dots + \dots\dots) \times 0,00981 = \text{kN} \dots\dots \leq \text{kN } 17,17$$

Dove: T = Massa complessiva max. della motrice (in Kg)

R = Massa rimorchiabile max. della motrice (in Kg)

DA COMPILARE PER IL COLLAUDO

FAC-SIMILE



umbrarimorchi.pl